

NOVE99+
SOLUTIONS

GARBELOTTO

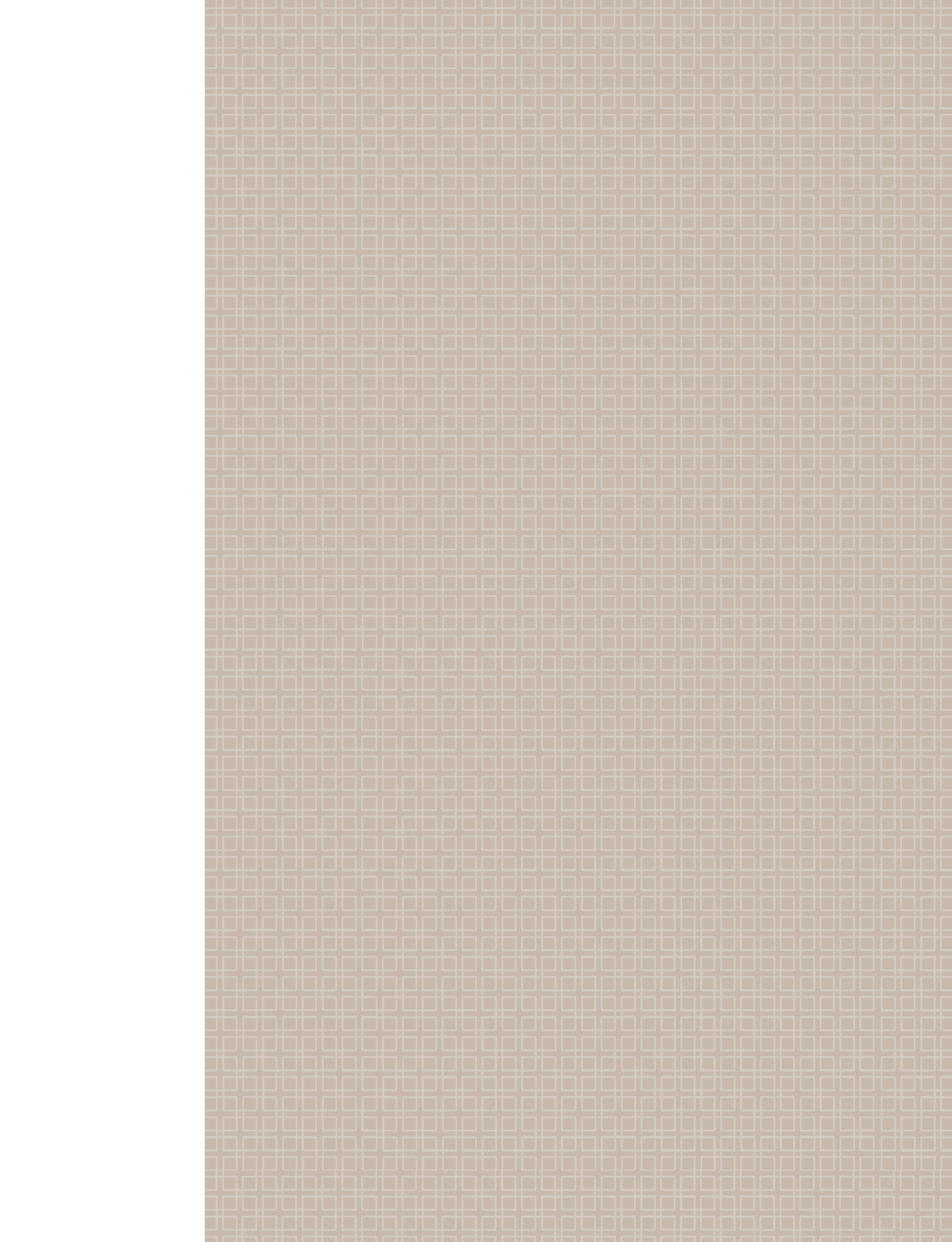



INDICE
INDEX

6

I nostri prodotti 100% Made in Italy li facciamo così

We make our 100% Made in Italy products in this way

7

Certificazioni
Certifications

8-9

Clip Up System®

10-11

Gamma specie legnose

Wood species range

12-18

Gamma cromatica Rovere

Oak finishes range

19-22

Le finiture
The finishes

23

Scelte
Selection

24-25

Trattamenti della superficie

Surface treatments

26-27

Geometrie di posa

Laying geometry

28

Listo Floor®



29-30

Master Floor®

31

I Gessi®

32

Xilema®

33

Gli Antichi
Antique

34-39

Creator®

40-41

Boiserie

42

Hi-Tech®

43

Decking

44

Complementi
per pavimenti
in legno
Complements
for wooden
floors

45

Componi
il tuo
pavimento
personalizzato
Create your
own custom
floor

I NOSTRI PRODOTTI 100% MADE IN ITALY LI FACCIAMO COSÌ:
WE MAKE OUR 100% MADE IN ITALY PRODUCTS IN THIS WAY:

I due strati vengono incollati solo con colla poliuretanicca ad alta tenuta e resistente all'umidità. Gli incastri micrometrici sui 4 lati, realizzati con tolleranza massima di 2 decimi di millimetro, assicurano la solidità tra le liste contigue ed una superficie estremamente compatta.

The two layers are glued only with high sealing polyurethane glue. The micrometric joints on 4 sides, made with maximum tolerance of 2 tenths of a millimetre, ensure an excellent stability and an extremely compact surface.

VERSIONE M/F 4 LATI - T/G 4 SIDES VERSION

Plancia legno nobile con spessore 3/4/6 mm.
 A richiesta è possibile avere altri spessori.
 3/4/6mm Top Layer. On request it is possible to have other thicknesses.

Supporto marino di betulla o similari a strati incrociati, certificato in classe E1.
 Crossed layers marine support in birch or similar wood E1 class certified.

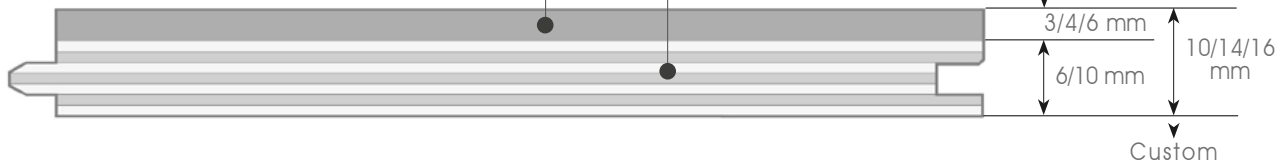

VERSIONE - VERSION **CLIPUP[®]**
 SYSTEM

Plancia legno nobile con spessore 3 mm.
 A richiesta è possibile avere altri spessori.
 3mm Top Layer. On request it is possible to have other thicknesses.

Supporto marino di betulla o similari a strati incrociati, certificato in classe E1.
 Crossed layers marine support in birch or similar wood E1 class certified.

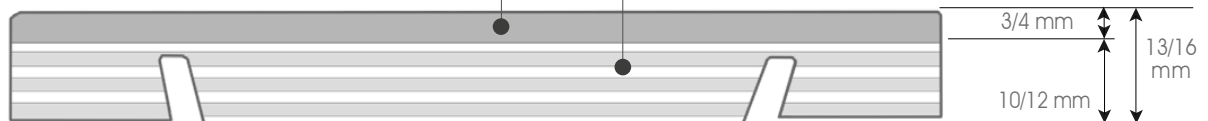

<p>Ecologico Eco-friendly</p>   <p>Classe di reazione al fuoco Fire reaction class</p>	<p>Customizzabile Customizable and in different wood species</p>   <p>Riscaldamento e raffreddamento a pavimento Underfloor heating</p>	<p>Frequente calpestio High traffic areas</p>   <p>Eco friendly</p>	<p>Comfort acustico Acoustic comfort</p>   <p>Massimo comfort High Comfort</p>	<p>Ristrutturazione Renovation</p>   <p>Facilmente igienizzabile e pulibile Easy to clean</p>
---	--	--	---	--

CERTIFICAZIONI CERTIFICATIONS

Le nostre certificazioni contribuiscono ad ottenere elevati punteggi nelle classificazioni Leed, Well e Breeam dei nuovi e futuri green building.

Our certifications contribute to high Leed, Well and Breeam grade classifications for new and future green buildings.



Dichiarazione ambientale di prodotto Garbelotto è la prima azienda di pavimenti in legno certificata EPD, che ne attesta la completa sostenibilità aziendale e di tutti i prodotti rispettando l'ambiente.

Environmental product declaration Garbelotto is the first EPD wooden floor company certified. All our establishments and all our products are sustainable and respect the environment.

 N° UNI-EN 14342	 FSC® FSC® C104219 The mark of responsible forestry	 AgBB EMISSIONS DANS L'AIR INTERIEUR A+ A B C	 Cfl-s1	 CI MADE IN ITALY CERTIFIED ITPI	 E1 HCHO CARB HCHO	
Certificazione CE CE certification	Certificazione FSC® FSC® certification	Alti standard qualitativi di benessere High well-being quality standards	Certificazione CFL S1 CFL - S1 Certification	Certificazione CI n° IT01. IT/340.039.M CI certification n° IT01. IT/340.039.M	Bassa emissione di formaldeide Low formaldehyde emission	Se vuoi saperne di più Discover more

TEST / TESTS	 VOC Verifica dei VOC VOC Verification	 Alto comfort acustico High acoustic comfort
--------------	---	--

Determinazione della Resistenza termica	Determination of thermal resistance
Quadrettatura	Cross cut test
Attrito sul Pavimento - Antisdrucciolo - Alto calpestio	Floor Friction Test - Anti-slip - High traffic (areas)
Determinazione della resistenza agli agenti chimici	Determination of resistance to chemical agents
Resistenza a cicli umido-secco	Wet-dry Cycles Resistance
Emissione di formaldeide	Formaldehyde emission



CLIP UP[®]
SYSTEM

PATENTED BY
GARBELOTTO



Se vuoi saperne di più
Discover more

SISTEMA DI POSA BREVETTATO SENZA COLLA PATENTED LAYING SYSTEM WITHOUT GLUE

Clip Up System[®] è l'innovativo sistema di posa flottante brevettato dal reparto Ricerca&Sviluppo del Parchettificio Garbelotto per posare il parquet in modo semplice e veloce, con il grande vantaggio di poter sostituire una o più tavole in meno di un minuto in qualsiasi parte della stanza.

Singole doghe o intere porzioni di pavimento possono essere rimosse senza nessun ostacolo e senza rovinare il piano di posa sottostante in quanto le clips non vengono fissate al massetto.

Clip Up System[®] dispone di tutte le certificazioni specifiche Garbelotto ed è utilizzabile in tutti gli spazi che richiedono norme restrittive o dove è necessaria la presenza di un pavimento ispezionabile.

Clip Up System[®] is the innovative floating installation system patented by the Research&Development department of Parchettificio Garbelotto for laying parquet quickly and easily, with the great advantage of being able to replace one or more planks in less than a minute even in the center of the room.

Single planks or entire portions of the floor can be removed without any obstacle and without damaging the underlying laying surface as the clips are not fixed to the screed.

Clip Up System[®] has all the specific Garbelotto certifications and can be used in all spaces that require restrictive standards or where the presence of an inspectable floor is required.

Prefinito flessibile con fresature longitudinali e trasversali in testa per inserimento clip.
Flexible prefinished wooden floor with lengthwise milling for clip insertion.

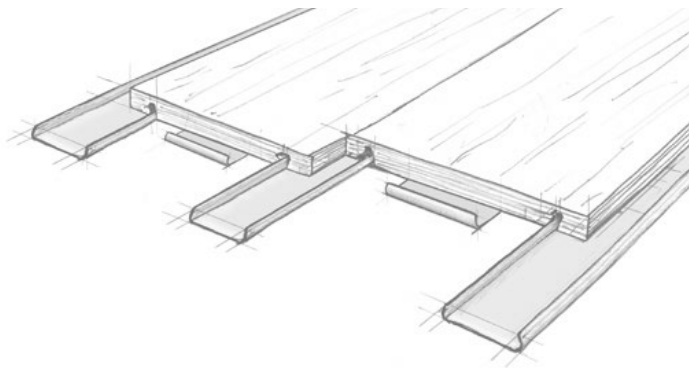

- 1 Clip in polimero 100% riciclabile.
100% recyclable polymer clip.
- 2 Classe 1 reazione al fuoco (CfIS1).
Class 1 fire reaction (CfIS1).
- 3 13/16 mm: 3/4 mm di legno nobile + 10/12 mm di multistrato in Betulla fenolica certificata o similari.
13/16 mm: 3/4 mm wood + 10/12 mm phenolic birch multilayer or similar, certified.
- 4 Materassino Clip Up System® 2 mm di spessore alta densità. Abbattimento acustico e barriera al vapore.
Clip Up System® mat 2 mm thick high density. Noise reduction and steam barrier.
- 5 Disponibile su tutta la gamma > mm 110 Larghezza
Available on the whole range > mm 110 Width
- 6 Le clip per posa a correre vengono fornite della lunghezza di un metro lineare, per le geometrie di posa e per le teste vengono fornite a misura.
The clips for the straight laying are supplied in pieces of one meter length, For other geometries and for the short heads the clips are supplied cut to length.

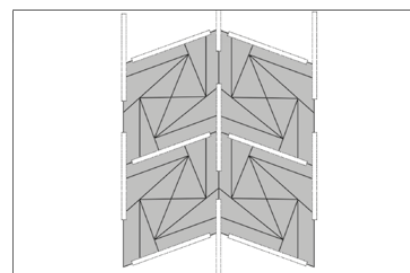

St. Barth / Montecarlo

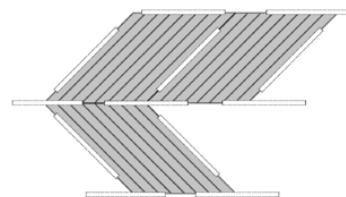

Spina modulare
Modular Herringbone

CLIP UP SYSTEM® | GEOMETRIE DI POSA

CLIP UP SYSTEM® | LAYING GEOMETRIES

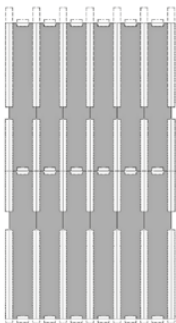
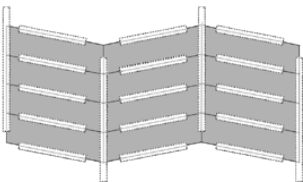
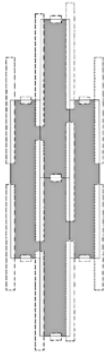
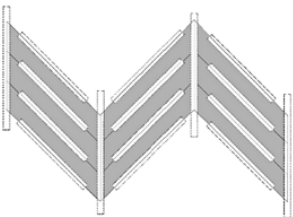
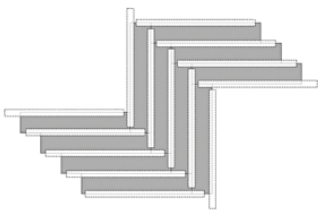
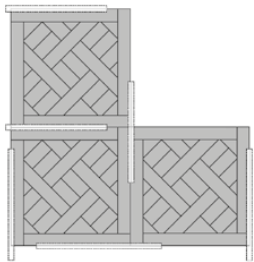
 <p>Posa dritta accostata "a sorella" Parallel pattern</p>	 <p>Spina Noblesse® angolo 10° Noblesse® Chevron 10° angle</p>	 <p>Posa a correre o cassero regolare Random or brick pattern</p>
 <p>Spina Noblesse® angolo 45°-60° Noblesse® Chevron 45°-60° angle</p>	 <p>Spina Destra e Sinistra angolo 90° Right and Left Herringbones 90° angle</p>	 <p>Linea CREATOR® CREATOR® Line</p>

GAMMA SPECIE LEGNOSE
WOOD SPECIES RANGE

ROVERE
OAK



TERMO ROVERE
THERMO OAK



ROVERE SMOKED
SMOKED OAK



ROVERE ANTICO
ANTIQUE
RECLAIMED OAK



IROKO



LARICE
LARCH



NOCE AMERICANO
AMERICAN WALNUT



NOCE NAZIONALE
EUROPEAN WALNUT



OLMO
ELM



TEAK



WENGÈ

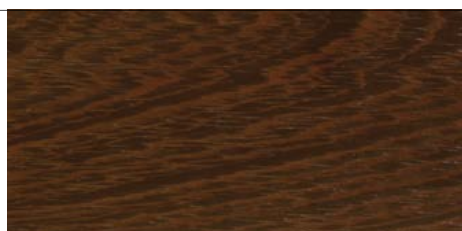
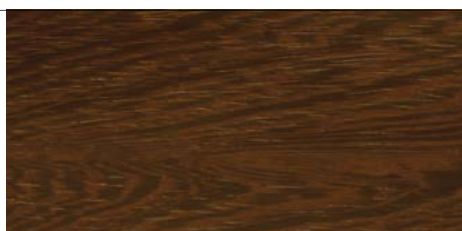

GAMMA CROMATICA ROVERE
OAK FINISHES COLOR RANGE

I NATURALI / THE NATURALS

NATURALE
NATURAL
COD. 00



ARIA
COD. AI



CÀ D'ORO
COD. CD



ÈCRU
COD. EU



SABBIA
COD. SB



GLI AMBRATI / THE AMBERS

DUCALE

COD. DU

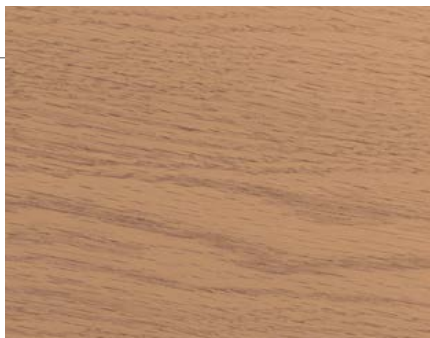

5 TERRE

COD. 5T



TERRE
FIORENTINE

COD. FT



MIELATO
HONEY
EFFECT

COD. 12



CIVETTA

COD. CI



Tutte le immagini sono indicative per tono, colore e scelta.
All images are indicative by tone, colour and choice.

GAMMA CROMATICA ROVERE
OAK FINISHES COLOR RANGE

I GRIGI NATURALI / THE NATURAL GREYS

TORTORA

COD. RR



MONACO

COD. MO



TRANI

COD. TA



VISONE

COD. VI



DOLOMITI

COD. DO



I GRIGI TECNICI / THE TECHNICAL GREYS

GRIGIO
CADETTO

COD. GC



GRIGIO
REALE

COD. GR



FANGO

COD. FN



GRIGIO
FOSSILE

COD. GS



QUARZO

COD. QZ



Tutte le immagini sono indicative per tono, colore e scelta.
All images are indicative by tone, colour and choice.

GAMMA CROMATICA ROVERE
OAK FINISHES COLOR RANGE

I PROVENZALI / THE PROVENCALS

SBIANCATO
VELATO
VEILED
BLEACHED

COD. 21



DECAPATO
SBIANCATO
PICKLED
BLEACHED

COD. 23



CENERE
DECAPATO
BIANCO
ASH
PICKLED
WHITE

COD. CB



OCRA
DECAPATO
PICKLED
OCHER

COD. OD



MOKA
DECAPATO
PICKLED
MOKA

COD. MD



I COLORI DELLA TERRA / THE COLORS OF THE EARTH

ANTICATO
CUOIO
ANTIQUED
LEATHER

COD. 11



TINTO
TERMO
TINTO
THERMO

COD. TT



TERRA
COTTA

COD. ET



BRUNITO

COD. BR



ACCADEMIA

COD. AC



Tutte le immagini sono indicative per tono, colore e scelta.
All images are indicative by tone, colour and choice.

GAMMA CROMATICA ROVERE
OAK FINISHES COLOR RANGE

GLI SPECIALI / THE SPECIALS

SBIANCATO
BLEACHED

COD. 20



SILVER

COD. 38



CHAMPAGNE

COD. CH



ROSA
ANTICO

COD. RA



MORCIATO
IMBUED

COD. 16



CORTEN

COD. CN



LE NOIR

COD. 42



NERO
BLACK

COD. 40

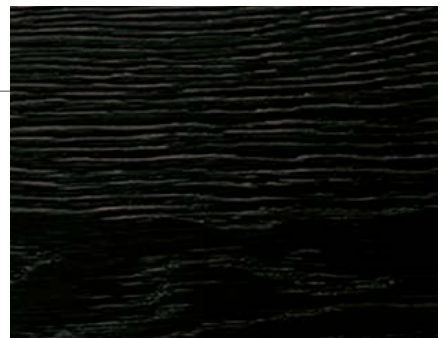



LE FINITURE THE FINISHES

HABITAT COD. HA

Habitat è una finitura della superficie che viene realizzata su tutte le specie legnose per garantire un effetto completamente naturale come il legno appena tagliato. Habitat preserva ed esalta la naturale matericità del legno, grazie ad una lavorazione che rende le tavole totalmente materiche per un vero effetto grezzo ma super protetto. La finitura è caratterizzata da un trattamento di verniciatura a ciclo completo all'acqua eco-friendly, nel quale viene utilizzato un particolare fondo creando una barriera che protegge dalla naturale ossidazione del legno. Alla vista il pavimento è naturale: le tonalità e le caratteristiche delle specie legnose non vengono alterate. Al tatto la superficie è morbida e piacevole: camminare a piedi nudi su un pavimento Habitat è un vero piacere sensoriale che accompagna il nostro benessere quotidiano e abitativo. Adatto a qualsiasi ambiente pubblico o privato grazie alla sua alta resistenza al calpestio. Disponibile su tutte le specie legnose non tinte.

HABITAT COD. HA

Habitat is a surface finish that is made on all the wood species. Boards are completely natural as real time-wood cut. Habitat preserves and enhances the natural texture of the wood, thanks to a process that makes the boards totally mat. The finish is characterized by a complete ecofriendly water-based painting treatment, in which a particular base is used which creates a barrier to the tannin of the wood and protects from thenatural oxidation of the wood. The floor is natural to the eye: the shades and characteristics of thewood species are not altered. To the touch the surface is soft and pleasant: walking barefoot on a Habitat floor is a real sensorial pleasure that accompanies our daily and living well-being. Suitable for any public or private environment thanks to its high resistance to foot traffic.

LE FINITURE

THE FINISHES

VERNICIATURA ALL'ACQUA

COD. V0 / V2

La verniciatura a ciclo completo all'acqua è ideale per la bioedilizia in quanto garantisce l'assenza totale di emissioni di sostanze tossiche. I suoi 120 gr/mq di vernice applicata e l'aggiunta di micro-particelle cerose rendono la superficie resistente e morbida al tatto. La finitura può essere effetto matt o cera.

WATER BASED VARNISH

COD. V0 / V2

Completely water based varnish, which is ideal for bio-building, grants a total absence of harmful emissions. A 120gr/sqm of applied varnish and the adding of waxy micro-particles make the surface resistant and smooth. The finish can be matt or wax effect.

FINITURA AD OLIO UV

COD. O2

La finitura ad olio è un processo di ultima generazione, adatto alla bioedilizia perché ecologico e privo di sostanze nocive e ad alta resistenza. Viene applicato un olio che nutre, protegge e preserva la superficie del legno, per un aspetto naturale e opaco.

UV OIL FINISH

COD. O2

The new natural oil finish is characterized by an innovative oil, suitable for bio-building because it is totally free from noxious substances and with high resistance. It is a natural oil that nourishes, protects and preserves the wood surface, for an appearance natural and matt.

VERNICIATURA EFFETTO GLOSS®

COD. V3

La verniciatura effetto Gloss è creata per rendere ancora più caratterizzanti i pavimenti in legno. I parquet prefiniti verniciati Gloss coniugano la ricercatezza del design e la resistenza e la praticità per dare vita a pavimenti dal finish brillante e unico. La finitura Gloss illumina gli ambienti con nuovi accenti di luce riflettonza.

GLOSS® EFFECT VARNISH

COD. V3

The Gloss varnish is a water-based painting designed to make the floor even more characterizing. The engineered, Gloss painted parquet combines the sophistication of design with the attention durability and practicality to create a brilliant wooden floor.

VERNICE ANTISCIVOLO E ALTO TRAFFICO

COD. V11 / V8

Disponibile su richiesta.

ANTI-SLIP VARNISH AND HIGH TRAFFIC VARNISH

COD. V11 / V8

Available on request.

FINITURA IMOMED (Settore navale)

COD. V9

Disponibile su richiesta.

IMOMED FINISH (Naval sector)

COD. V9

Available on request.

GREZZO NON VERNICIATO

COD. 50NV

Disponibile su richiesta.

RAW UNVARNISHED

COD. 50NV

Available on request.

FINITURE V0/V2/O2/V3
V0/V2/O2/V3 FINISHES

FINITURA HABITAT HA
HABITAT FINISHES HA

ROVERE
OAK



TERMO ROVERE
THERMO OAK



ROVERE SMOKED
SMOKED OAK



ROVERE ANTICO
ANTIQUE
RECLAIMED OAK



IROKO



FINITURE V0/V2/O2/V3
V0/V2/O2/V3 FINISHES

FINITURA HABITAT HA
HABITAT FINISHES HA

LARICE
LARCH

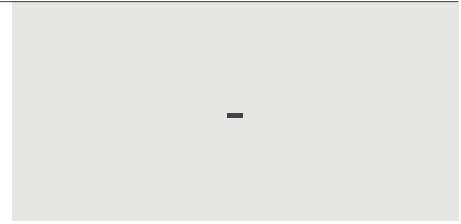

NOCE AMERICANO
AMERICAN WALNUT



NOCE NAZIONALE
EUROPEAN WALNUT



OLMO
ELM



TEAK



WENGÈ

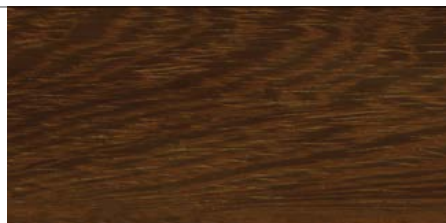

SCELTE SELECTION

UNICA
UNIQUE
COD. 03



triangolo / triangle
NORMA UNI EN 13489



Rigato largo e fiammato. Nodi consentiti inferiori ad 8 mm circa di diametro per il Rovere e inferiori a 5 mm circa di diametro per le Latifoglie.

Wide and flamed striped. Permitted knots less than about 8 mm in diameter for Oak and less than about 5 mm in diameter for Hardwoods.

RUSTICA
RUSTIC
COD. 04



quadrato / square
NORMA UNI EN 13489



Può presentare stonalizzazione, tracce di albarno, nodo anche di grandi dimensioni stuccato e piccole fessurazioni. Rimangono non consentite caratteristiche che possono compromettere resistenza o qualità di resistenza all'usura.

It has shading, traces of sapwood, a large plastered knot and small fissures. Characteristics that may compromise strength or wear-resistance qualities are not permitted.

IMPORTANTE / IMPORTANT

▲ **SCELTA UNICA / UNIQUE SELECTION** (triangolo/triangle)

■ **SCELTA RUSTICA / RUSTIC SELECTION** (quadrato/square)

Per le classi di aspetto qualitative delle diverse specie legnose, l'Azienda rispetta le specifiche espletate all'interno della Normativa Europea UNI EN 13489 come riportato sul nostro listino.

For the qualitative appearance classes of the different wood species, the Company complies with the specifications carried out within the European Standard UNI EN 13489 as referred in our price list.

TRATTAMENTI DELLA SUPERFICIE

SURFACE TREATMENTS

Caratteristiche: i pavimenti con lavorazioni particolari della superficie e i legni antichi, presentano le caratteristiche di aspetto tipiche delle lavorazioni artigianali o del tipo di prodotto. Le differenze che si rilevano tra elemento ed elemento anche all'interno dello stesso (stonalizzazioni di colore, planarità e rugosità della superficie) non rappresentano un difetto ma costituiscono delle particolarità e aumentano il valore aggiunto della lavorazione artigianale del prodotto. Alcune lavorazioni di superficie praticate su alcuni prodotti generano sbazzature, asperità e piccole scheggiature che possono costituire da appiglio per gli stracci utilizzati nelle operazioni di pulizia. Tutto quanto indicato costituisce un elemento di valutazione da attenzionare in maniera particolare sulla destinazione del prodotto.

Features: the floors with particular surface treatments and ancient woods, have the typical appearance characteristics of craftsmanship or of the type of product. The differences that are found between element and element even within it (color shading, flatness and roughness of the surface) do not represent a defect but constitute the peculiarity and an added value of the craftsmanship of the product. Some surface treatments carried out on some products generate roughness, and small slivers that can act as a grip for the rags used in cleaning operations. All of the above constitutes an element of evaluation to pay particular attention to when the floor will be used.

LISCIO
PORO APERTO
SMOOTH
OPEN PORE
COD. LI



Liscio a poro aperto è una particolare lavorazione di Garbelotto; il trattamento rimane in superficie rendendola liscia, mantenendo il poro aperto per una maggiore naturalezza. Questo tipo di lavorazione fa risultare le tavole molto luminose, compatte ed omogenee al tatto.

Smooth open pore is a particular Garbelotto crafting; the treatment remains on the surface allowing a smooth surface but while keeping the pore open for greater naturalness. This type of processing makes the boards very bright and compact and homogeneous to the touch.

SPAZZOLATO
BRUSHED
COD. SP



La spazzolatura si realizza tramite un processo con il quale alla superficie di ogni tavola, con l'utilizzo di speciali spazzole idonee, viene asportata la parte più tenera del legno senza rovinarne le fibre, evidenziandone la sua naturalezza.

Brushing takes place through a process by which the softest part of the wood is removed from the surface of each board, with the use of special suitable brushes, without damaging its fibres, highlighting its naturalness.

PIALLATURA
A MACCHINA
MACHINERY
PLANED

COD. PI



Effetto regolare discontinuo. Pregiata lavorazione
effettuata tavola per tavola, ottenuta con macchinari
industriali speciali.

Discontinuous regular effect. A fine working realized
board by board, obtained with special industrial
machinery.

PIALLATURA
A MANO
HAND-MADE
PLANED

COD. PA



Effetto irregolare discontinuo. Pregiata lavorazione,
ottenuta manualmente con pialla da abili maestri
ebanisti tavola per tavola.

Irregular discontinuous effect. Precious
workmanship, obtained manually with a plane by
skilled cabinet-makers table by table.

TRAMA

COD. TR



Trattamento che conferisce un aspetto materico alla
superficie riproducendo la fitta trama dei tessuti.

Treatment that adds a special effect to the surface,
reproducing the thick fabric texture.

TAGLIO SEGA
SAWN EFFECT

COD. TS



Trattamento di incisione trasversale che riproduce
la segagione di una volta.

Treatment made of transversal cuts on the boards
as in former times.

GEOMETRIE DI POSA

LAYING GEOMETRY

Per geometria di posa si intende il disegno che nasce dall'accostamento dei singoli elementi che compongono una pavimentazione in legno. Le loro dimensioni, l'uso di mosaici sia di tipo geometrico che non geometrico e la creatività nell'accostarli, sono i fattori che determinano la composizione decorativa finale.

For laying geometry is meant the design that comes from the combination of individual elements that make up a wooden flooring. Their dimensions, the use of geometric and non-geometric mosaics, and the creativity in combining them, are the factors that determine the final decorative composition.

SPINA DESTRA E SINISTRA 90°
RIGHT AND LEFT HERRINGBONE 90°

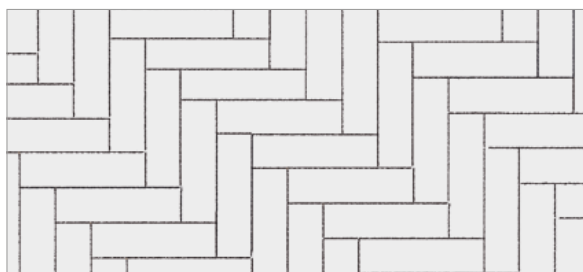

COD. DS

SPINA DESTRA E SINISTRA 90° DOPPIA
RIGHT AND LEFT HERRINGBONE 90° DOUBLE

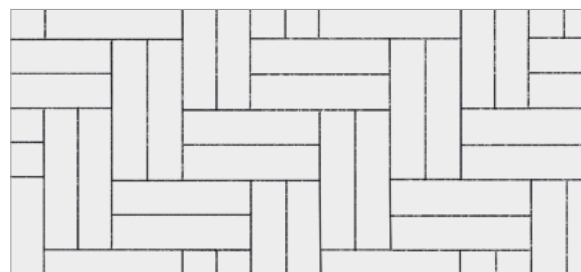

COD. DU

SPINA NOBLESSE® 45°/60°
NOBLESSE® HERRINGBONE 45°/60°

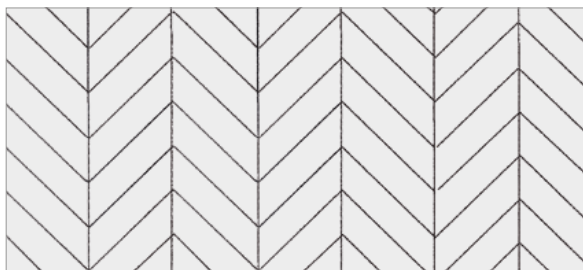

COD. NB

SPINA NOBLESSE® TRIPLA 3 LARGHEZZE
NOBLESSE® HERRINGBONE TRIPLA 3 WIDTHS



COD. TP

SPINA NOBLESSE® DUPLA 2 LUNGHEZZE
NOBLESSE® HERRINGBONE DUPLA 2 LENGTHS

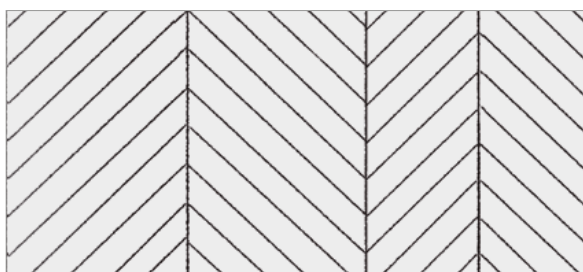

COD. DP

SPINA NOBLESSE® POSA A CORRERE
STRAIGHT LAYING HERRINGBONE NOBLESSE®

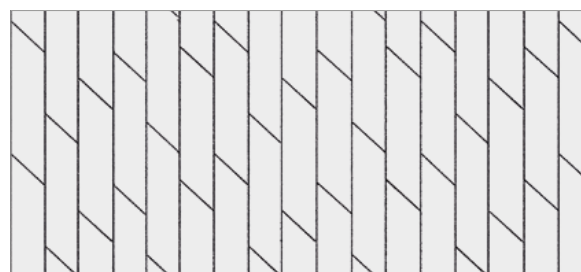

COD. PC

SPINA NOBLESSE® ANGOLO 10°
NOBLESSE® HERRINGBONE 10° ANGLE

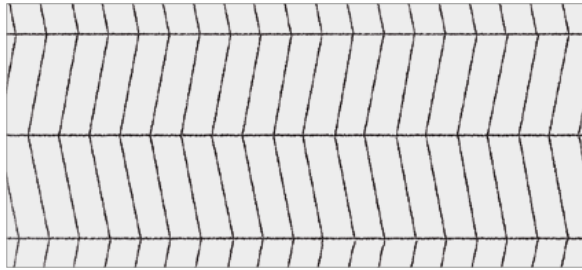

COD. 10°

SPINA MODULARE
MODULAR HERRINGBONE

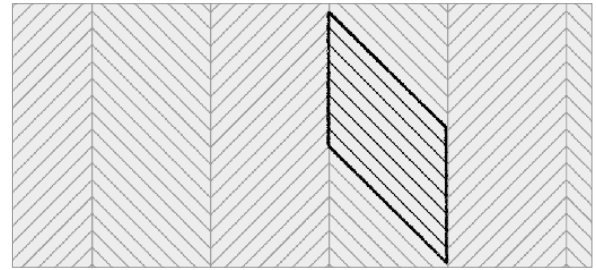

COD. SM

SAINT MORITZ
SAINT MORITZ

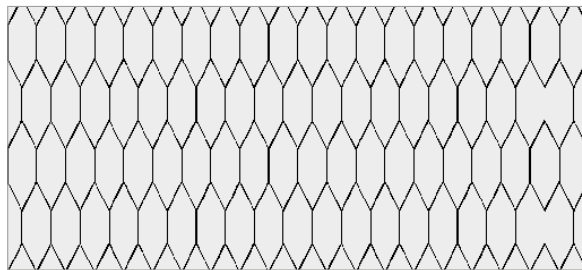

COD. MZ

SAINT TROPEZ
SAINT TROPEZ

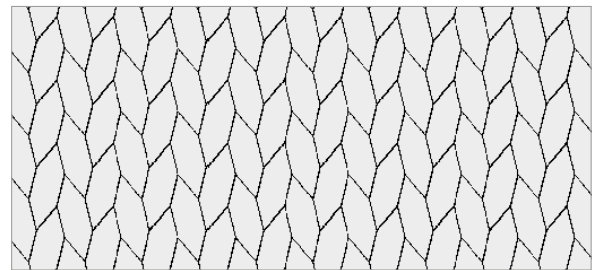

COD. ST

SAINT BARTH
SAINT BARTH

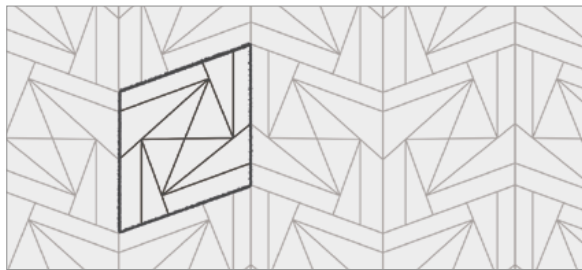

COD. SB

MONTECARLO
MONTECARLO

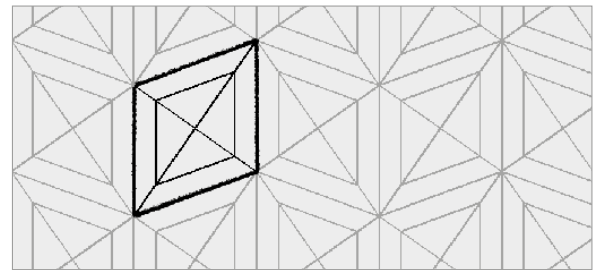

COD. MC

BALI
BALI

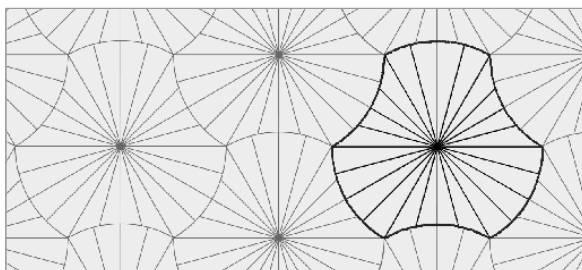

COD. BL

QUADROTTE
SQUARE COMPOSITIONS

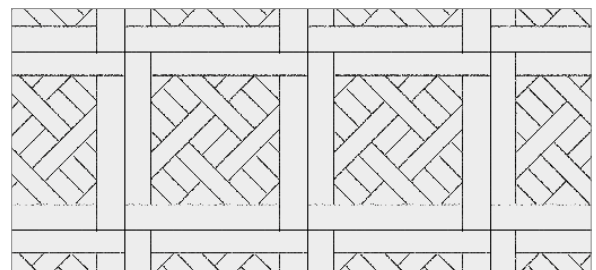

















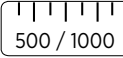



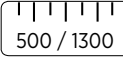

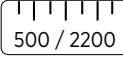

Se vuoi saperne di più
Discover more

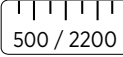

LISTO FLOOR®

Un prodotto moderno che mantiene le caratteristiche di pregio dei parquet con 4 mm di legno nobile ma con un basso spessore per tutte le esigenze di ristrutturazione e non. Ancora più prestazionale per i sistemi di riscaldamento a pavimento è disponibile in tutti i formati e geometrie di posa del catalogo Garbelotto. Prodotto adatto alla sola posa incollata.

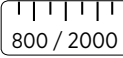
A modern product that maintains the quality characteristics of parquet with 4 mm of noble wood but with a low thickness for all restructuring and non-renovation needs. Even more performing for underfloor heating systems, it is available in all formats and installation geometries in the Garbelotto catalogue. Product suitable for glued installation only.

							
BASIC					•	•	•
MAXI					•	•	•
GRAND					•	•	•
GOLD					•	•	•
GOLD XXL					•	•	•



















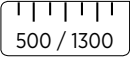



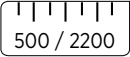

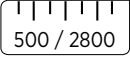

Se vuoi saperne di più
Discover more

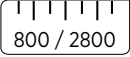

MASTER FLOOR®

Il più tradizionale degli spessori del parquet prefinito di qualità, disponibile in tutta la gamma Garbelotto fino a larghezze di 250 mm. Il legno nobile con spessore di 4 mm viene abbinato ad una struttura di multistrato di Betulla da 10 mm ottenendo una stabilità massima e la possibilità di essere posato incollato o flottante. Disponibile in versione M/F 4 lati o in versione Clip Up System® per una posa moderna ed ecologica.

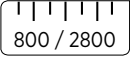
The noble wood with a thickness of 4 mm is combined with a 10 mm birch plywood structure obtaining maximum stability and the possibility of being laid glued or floating. Available in the T/G 4-sided version or in the Clip Up System® version for a modern and ecological installation.

								
SUPER					•	•	•	
ELEGANT					•	•	•	•
CLASSIC					•	•	•	•
BIG OLD					•	•	•	•
BIG OLD XXL					•	•	•	•



















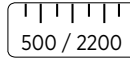

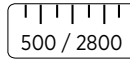

Se vuoi saperne di più
Discover more

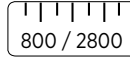

MASTER FLOOR® PRESTIGE®

Il massimo del parquet per chi vuole spessori importanti e durata infinita del pavimento. La qualità Garbelotto abbinata ad uno spessore del legno nobile di 6 mm. Come ListoFloor® e Master Floor® è disponibile in tutte le finiture e geometrie di posa.

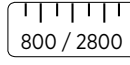
The best of parquet for those who demand important thicknesses and infinite duration of the floor. Garbelotto quality combined with a noble wood thickness of 6 mm. Like ListoFloor® and Master Floor® it is available in all finishes and laying patterns.

							
				•	•	•	
				•	•	•	•
				•	•	•	•
				•	•	•	•



I GESSI®



Se vuoi saperne di più
Discover more

I Gessi®: un prefinito di Rovere e altre specie legnose in tavole lunghe e strette (larghezza 70 mm e lunghezze fino a 1600 mm) disponibile anche nel formato Spina versione Noblesse® e Destra e Sinistra. I Gessi® è una linea che prende ispirazione dagli anni 70 e 80, dona un aspetto vintage ma allo stesso tempo moderno e non convenzionale agli ambienti.

È possibile installarlo con posa dritta accostata "sorella".

I Gessi®: a pre-finished oak or other wood species in long and narrow planks (70 mm wide and lengths up to 1600 mm) also available in the Herringbone format, Noblesse® version and Right and Left. I Gessi® is a line that takes inspiration from the 70s and 80s, giving a vintage but at the same time modern and unconventional look to the environments.

It is possible to install it parallel pattern laying.

14	70	900 / 1600	4 mm 10 mm	•	•	•



XILEMA®



Se vuoi saperne di più
Discover more

Garbelotto dona una seconda vita al legno. Nelle foreste è facile imbattersi in tronchi di vecchi alberi "morti" in piedi, spesso di forme bizzarre: sono piante morte naturalmente nel bosco e che rimangono per anni abbandonate. In Garbelotto nasce così una linea che le recupera e valorizza questi tronchi realizzando pavimenti in legno dall'aspetto antico e materico e dalle tonalità uniche. La linea Xilema®, quindi, valorizza un materiale straordinario che dona all'ambiente in cui viene posato un'eleganza particolare e senza tempo nel pieno rispetto della natura.

Garbelotto gives a second life to wood. In forests it is easy to come across trunks of old trees standing "dead", often bizarre shapes: they are plants that have died naturally in the woods and which remain abandoned for years. Thus, Garbelotto gives birth to a line that recovers and enhances these trunks, creating wooden floors with an aspect of antiquity, age-old matter, and unique shades. Xilema® line, therefore, enhances an extraordinary material that gives to the environment in which it is laid a particular and timeless elegance.

					
14	180 250	1000 / 2500	4 mm 10 mm	•	•



GLI ANTICHI ANTIQUE



Se vuoi saperne di più
Discover more

Legno antico di 100% originale di recupero in diverse larghezze e lunghezze.

Abilmente trattato da mani esperte, se questi pavimenti potessero parlare racconterebbero storie passate. Il vero legno antico abilmente recuperato, scelto e trattato è pronto per essere posato nelle abitazioni nelle quali l'eco del passato rivive nel presente. Prefinito 2 strati in Rovere con spessore di 14 mm, fornito in diverse larghezze e lunghezze irregolari finito a mano con cere naturali. Pavimenti di recupero senza tempo unici e irripetibili!

Reclaimed antique wood 100% original in different widths and lengths.

If these floors could talk, they would speak of stories from the past. The real ancient wood skilfully recovered, chosen and treated is ready to be laid in homes where the echo of the past relives in the present. Pre-finished 2 layers Oak with a thickness of 14 mm, supplied in different widths and lengths, irregularly finished by hand with natural waxes. Timeless recovery floors, unique and unrepeatable!

14	110 300	500 / 2900	4 mm 10 mm	
----	------------	------------	---------------	---





LINEA CREATOR® CREATOR® LINE



Se vuoi saperne di più
Discover more

La linea CREATOR® è la nostra linea top di gamma fatta a mano, pezzo per pezzo, da abili maestri ebanisti, dedicata ai pavimenti artistici adatta a tutti gli ambienti, sia moderni e ricercati che classici e raffinati, pensata per creare un pavimento intramontabile

CREATOR® line is our top-of-the-range handmade line, piece by piece, by skilled master cabinet makers, dedicated to artistic floors suitable for all environments, both modern and distinguished; classic and refined, designed to create a timeless floor.

CLIPUP®
SYSTEM

INTARSI
INLAYS

GEOMETRIE ARTISTICHE ARTISTIC GEOMETRY	14				*
QUADROTTI SQUARE COMPOSITIONS	14	670 / 670	800 / 800 approx	4 mm 10 mm	•
TAPPETI CARPETS	14	600 / 600			
ROSONI DECORATIONS	14	800 / 800	Ø 800		
CORNICI FRAMES	14	140			

* Dipende dall'articolo / It depends on the item



CREATOR®

SPINA
MODULARE
MODULAR
HERRINGBONE

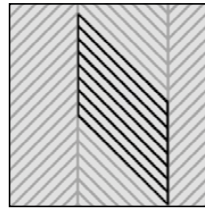

ST. MORITZ
COD. MZ

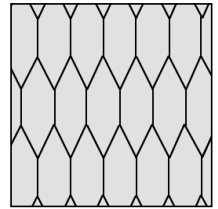

MONTECARLO
COD. MC

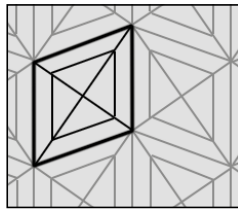

ST. MARTIN
COD. MR

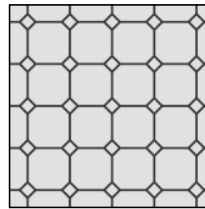

ST. TROPEZ
COD. ST

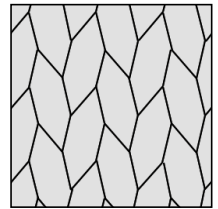

ST. BARTH
COD. SB

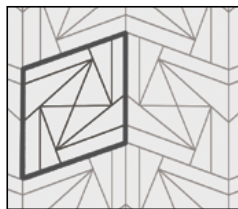

BALI
COD. BL

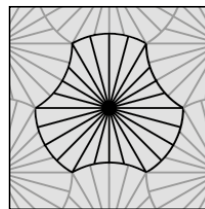

BODRUM
COD. BO

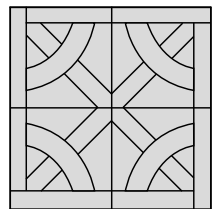

GEOMETRIE ARTISTICHE

Il team di architetti per la Ricerca&Sviluppo e gli interior designer di Garbelotto hanno progettato nuove geometrie di posa "artistiche" da installare negli ambienti moderni, dal design ricercato e che amano distinguersi.

ARTISTIC GEOMETRY

The team of architects for Research & Development and the interior designers of Garbelotto have designed new "artistic" installation geometries to be installed in modern environments, with a sophisticated design and which love to stand out.



LE QUADROTTE DI CREATOR® CREATOR® SQUARE COMPOSITIONS



Se vuoi saperne di più
Discover more

Sempre attuali e preziose, le Quadrotte arricchiscono gli ambienti dando un valore aggiunto all'ambiente, facendolo diventare unica ed originale. Grazie all'incastro sui 4 lati possono essere posate velocemente sia in diagonale che in orizzontale/verticale garantendo la massima stabilità e senza bisogno di ulteriori lavorazioni dopo la posa. Adatta a tutti gli ambienti, sia i più moderni e ricercati che quelli classici e raffinati, la nostra linea di Quadrotte è ricca di disegni senza tempo, per un pavimento intramontabile che non passa mai di moda. L'alta qualità del prodotto è garantita dall'esperienza dei nostri artigiani, che, come un tempo, compongono a mano ciascun riquadro.

Always current and precious, the Quadrotte enrich the environments giving added value to the location, making it unique and original. Thanks to the joint on 4 sides, they can be quickly installed both diagonally and horizontally/vertically, guaranteeing maximum stability and without the need for further work after installation. Suitable for all locations, both the most modern and refined and the classic and refined ones, our line of Quadrotte is full of timeless designs, for a timeless floor that never goes out of fashion. The high quality of the product is guaranteed by the experience of our craftsmen, who, as in the past, compose each square by hand.



LE MURRINE VENEZIANE DI CREATOR® VENETIAN CREATOR® WITH MURRINA



Se vuoi saperne di più
Discover more

Il vetro dell'antica arte veneziana incontra la magia del legno. Nasce così l'eleganza unica delle nostre Murrine. In un connubio perfetto tra natura e arte, legno e vetro si alternano formando delle vere e proprie opere d'arte. Il vetro dell'isola di Murano di Venezia originale, 100% certificato, lavorato a mano, cotto nelle fornaci e incastonato con splendide Murrine, si fonde alla nostra linea di Quadrotte Creator®. La possibilità di creare il proprio disegno a piacere scegliendo tra diversi modelli, studiati e realizzati in collaborazione con maestri vetrai, è un'opportunità unica.

Disponibile per Spine e linea Creator®.

**Dimensioni variabili a seconda del modello scelto.
Si rimanda alla consultazione del listino prezzi.**

The ancient Venetian art meets the magic of wood. Thus the unique elegance of our Murrine is born. In a perfect blend of art and nature, wood and glass alternate forming real works of art. The original Murano glass, 100% certified, hand-worked, cooked in the kilns and embellished with beautiful Murrines, blends in with our Creator® line Quadrotte (Square compositions). The opportunity to create your own design by choosing from different models, studied and realized in collaboration with glass masters, is a unique opportunity.

Available for Herringbones and Creator® line.

**Dimensions vary depending on the model chosen.
Please refer to the price list.**

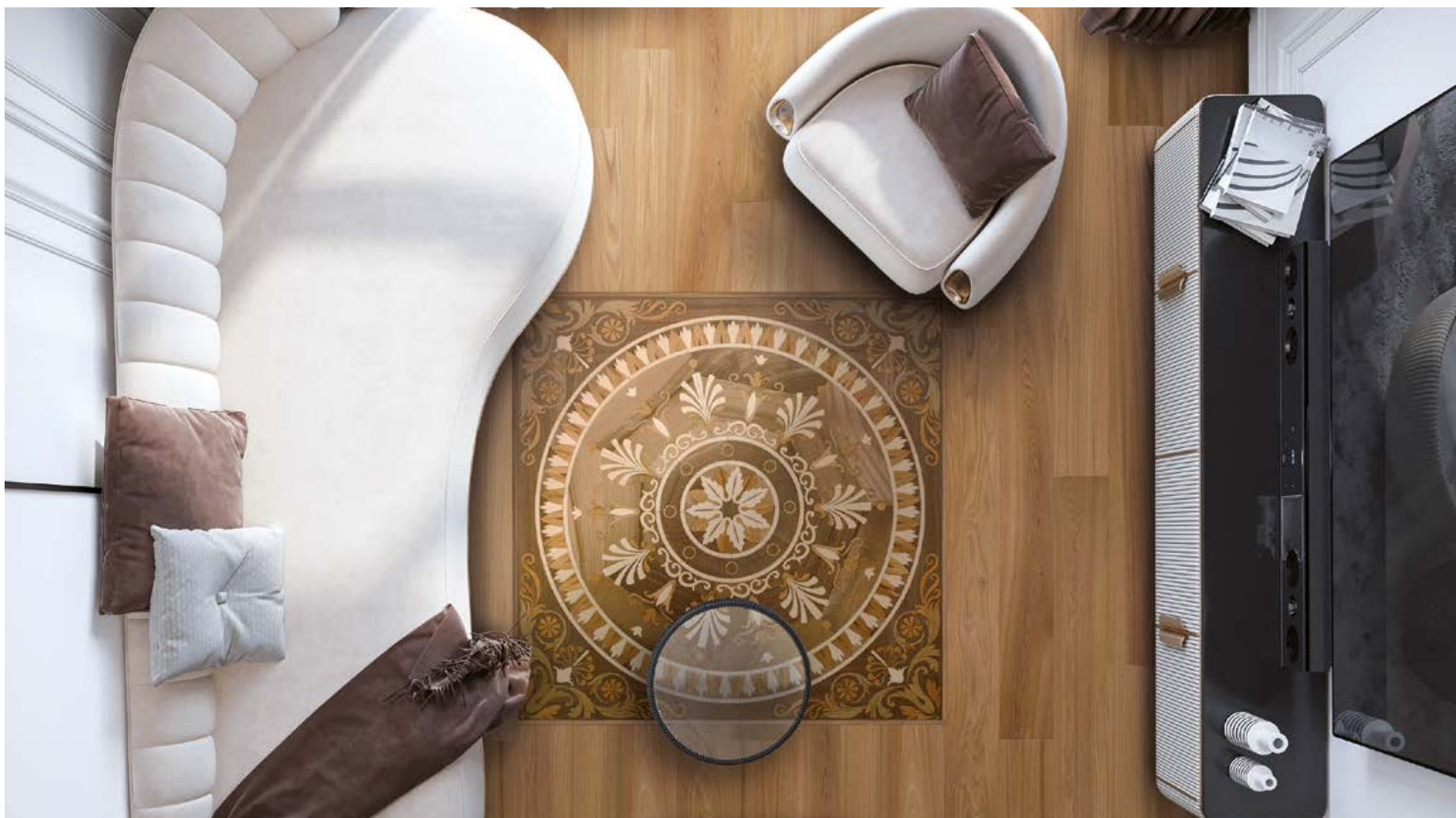

GLI INTARSI DI CREATOR® THE CREATOR® INLAYS



Se vuoi saperne di più
Discover more

La linea Intarsi di Creator® è composta da **rosoni, I tappeti, cornici**. I rosoni (o centri), sono delle decorazioni che adornano la parte centrale del parquet, rendendolo ancora più prezioso ed elegante. Possono riprodurre rose dei venti, stelle, tele di ragno, rombi e quadrati intrecciati a nodo, losanghe, girandole, fiori e molte altre composizioni con tantissime possibilità di personalizzazione. I tappeti nascono per pavimentazioni a tutto campo, ottenuti tramite ripetizione, l'accostamento e la combinazione di forme. L'accostamento di legni decorati e preziosi fa sì che la pavimentazione acquisti molteplici tonalità di eccezionale effetto. Ma è soprattutto la scelta della forma e delle decorazioni a dar origine alle più diverse geometrie, consentendo soluzioni d'arredo personalizzate. Tutti i nostri tappeti sono progettati e costruiti a mano all'interno del Parchettificio Garbelotto. I nostri artigiani esperti possiedono il talento, la visione e l'esperienza per trasformare ogni ambiente in un'opera d'arte dando vita ad ambienti più unici che rari. Le cornici sono delle decorazioni che adornano il parquet disegnando un perimetro che suddivide il pavimento della stanza in una parte interna e in una parte esterna. Grazie a questo elemento è possibile avere ulteriori possibilità di personalizzazione con cui rendere ricca ed elegante ogni stanza, a partire dal pavimento.

The Creator® Inlays line is made up of **rosettes, carpets and frames**.

Rosettes (or centers), are decorations that adorn the central part of the wooden floor, making it even more precious and elegant. They can reproduce wind roses, stars, spider canvases, diamonds and knotted squares, lozenges, wreaths, flowers and many other compositions with lots of customization options.

Carpets are created for flooring, obtained through repetition, the combination and the combination of shapes. The combination of decorated and precious wood makes the flooring acquire many shades of exceptional effect. But it is above all the choice of shape and decoration to give rise to the most different patterns, enabling custom furnishing solutions. All of our carpets are designed and built by hand within the Parchettificio Garbelotto site. Our experienced artisans have the talent, vision and experience to transform every space into a work of art that gives life to more unique than rare environments. Frames are decorations that adorn the parquet by designing a perimeter that divides the floor of the room into an interior and an exterior. Thanks to this element you can have further customization options to make rich and elegant every room, starting from the floor.



BOISERIE



Se vuoi saperne di più
Discover more

Il legno è un materiale nobile, in grado di donare calore ad ogni ambiente. Usarlo soltanto per il pavimento, a volte, è riduttivo.

Le linee di parquet Garbelotto sono adatte anche a rivestire superfici di tipo diverso, come pareti e soffitti.

In Francia, a cavallo tra il Seicento e il Settecento, infatti, il legno era uno dei materiali più diffusi anche per la realizzazione di eleganti boiserie, che ancora oggi decorano i più importanti palazzi nobiliari.

La boiserie è il rivestimento a parete che arricchisce gli ambienti rendendoli veri e propri elementi di design, attribuendo un tocco di ricercatezza, stile ed unicità e innalzando il comfort acustico, termico e abitativo.

Wood is a noble material that can give warmth to any space. To use it only for flooring, sometimes, it is almost reductive.

Garbelotto's parquet lines are also suitable for covering different kind of surfaces such as walls and ceilings. In France, between the seventeenth and eighteenth Century, wood was one of the most popular materials for the construction of elegant boiseries, which still decorate the most important royal palaces today.

The boiserie is the wall covering that enriches the rooms making them real design elements, giving a touch of refinement, style and uniqueness and increasing the acoustic, thermal and living comfort.



BOISERIE MATERIA 3.0



Se vuoi saperne di più
Discover more

Sistema di rivestimento per pareti realizzato con Conifera di recupero antica prima e seconda patina. Diversi formati, spessori, tipologie per donare un effetto tridimensionale alla superficie rivestita. Pre montati su pannelli M/F 4 lati come un patchwork sono facilmente installabile a parete con la massima velocità.

Wall cladding system made with first and second patina reclaimed Conifer. Different formats, thicknesses, types to give a three-dimensional effect to the covered surface. Pre-assembled on 4-sided T/G panels like a patchwork that can be easily and quickly installed on the wall.

14/16

180

1300 / 1500

3/6 mm
10 mm



HI-TECH®



Se vuoi saperne di più
Discover more

HI-TECH® è un giunto in PVC color nero con incastro maschio femmina applicabile su tutti i prefiniti con uno spessore da 10 o 14 mm, in tutte le specie legnose, per realizzare delle pose modello navale. Con il profilo HI-TECH® tutti i nostri parquet possono trasformarsi velocemente in pavimenti in legno "modello navale" particolari e innovativi, adatti ad ambienti interni ma non ad aree scoperte.

HI-TECH® is a black PVC joint with male female joint applicable on all pre-finished products with a thickness of 10 or 14 mm, in all wood species, to create naval model installations. With the HI-TECH® profile, all our parquets can quickly be transformed into particular and innovative "naval model" wooden floors, suitable for internal environments but not for open areas.



DECKING



Se vuoi saperne di più
Discover more

Ideale per la pavimentazione di bordi piscine, terrazze, camminamenti, balconi, patii, logge e rivestimenti esterni. Il pavimento decking Garbelotto è la soluzione ideale per rendere eleganti anche gli spazi dedicati al relax e all'aria aperta.

È disponibile nelle versioni in Bamboo, Ipè Lapacho e Teak Asia o Africa.

Ideal for paving pool edges, terraces, walkways, balconies, patios, loggias and external coverings. The Garbelotto decking floor is the ideal solution for making even spaces dedicated to relaxation and the open air elegant.

It is available in Bamboo, Ipè Lapacho and Teak Asia or Africa versions.



COMPLEMENTI PER PAVIMENTI IN LEGNO COMPLEMENTS FOR WOODEN FLOORS

Se vuoi saperne di più
Discover more

Garbelotto ti propone una gamma completa di complementi per pavimenti in legno, quali tori, soglie, battiscopa, complementi coordinati e rivestimento scale, prodotti per la posa, per la pulizia e manutenzione.

Garbelotto offers you a complete range of accessories for wooden floors, such as stairnosés, sills, skirting boards, coordinated accessories and stair coverings, products for laying, for cleaning and maintenance.

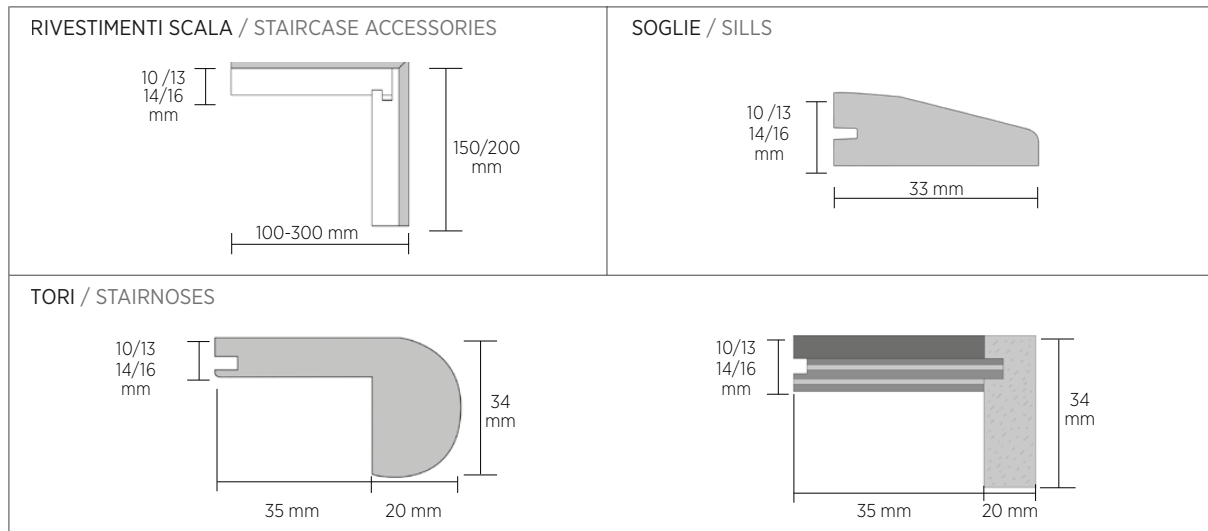



COMPONI IL TUO PAVIMENTO PERSONALIZZATO CREATE YOUR OWN CUSTOM FLOOR

Il Parchettificio Garbelotto offre infinite possibilità di personalizzazione ed è attrezzato per eseguire lavori customizzati. La nostra mission è incontrare e soddisfare le esigenze dei clienti, eseguire ogni tipo di geometria di posa, finiture della superficie e consigliare il giusto colore, partendo dalla materia prima certificata proveniente da zone con riforestazione controllata. L'azienda è sempre attenta alle nuove influenze provenienti dal mondo della moda e dell'interior design collaborando con architetti internazionali e archistar, realizzando prodotti 100% Made in Italy firmati artigianalmente da maestri ebanisti. L'unico pavimento personalizzabile e naturale non può che essere il legno il quale ci permette di realizzare un parquet dall'aspetto unico e originale. I pavimenti Garbelotto sono adatti alle residenze private, agli uffici, all'hotellerie, ai negozi, alle strutture pubbliche, ai teatri, musei, asili o a qualsiasi altro ambiente sia interno che esterno dove il legno possa essere protagonista di una storia, la vostra.

The Parchettificio Garbelotto offers infinite possibilities for customization and is equipped to perform customized works. Our mission is to meet and satisfy customer needs, perform any type of laying geometry, surface finishes and recommend the right colour, starting from the certified raw material from areas with controlled reforestation. The company is always attentive to new influences from the world of fashion and interior design by collaborating with international architects and archistar, creating 100% Made in Italy products handcrafted by master cabinetmakers. The only customizable and natural floor can only be wood which allows us to create a parquet with a unique and original appearance. Garbelotto floors are suitable for private residences, offices, hotels, shops, public structures, theatres, museums, kindergartens or any other internal or external environment where wood can be the protagonist of a story, yours.

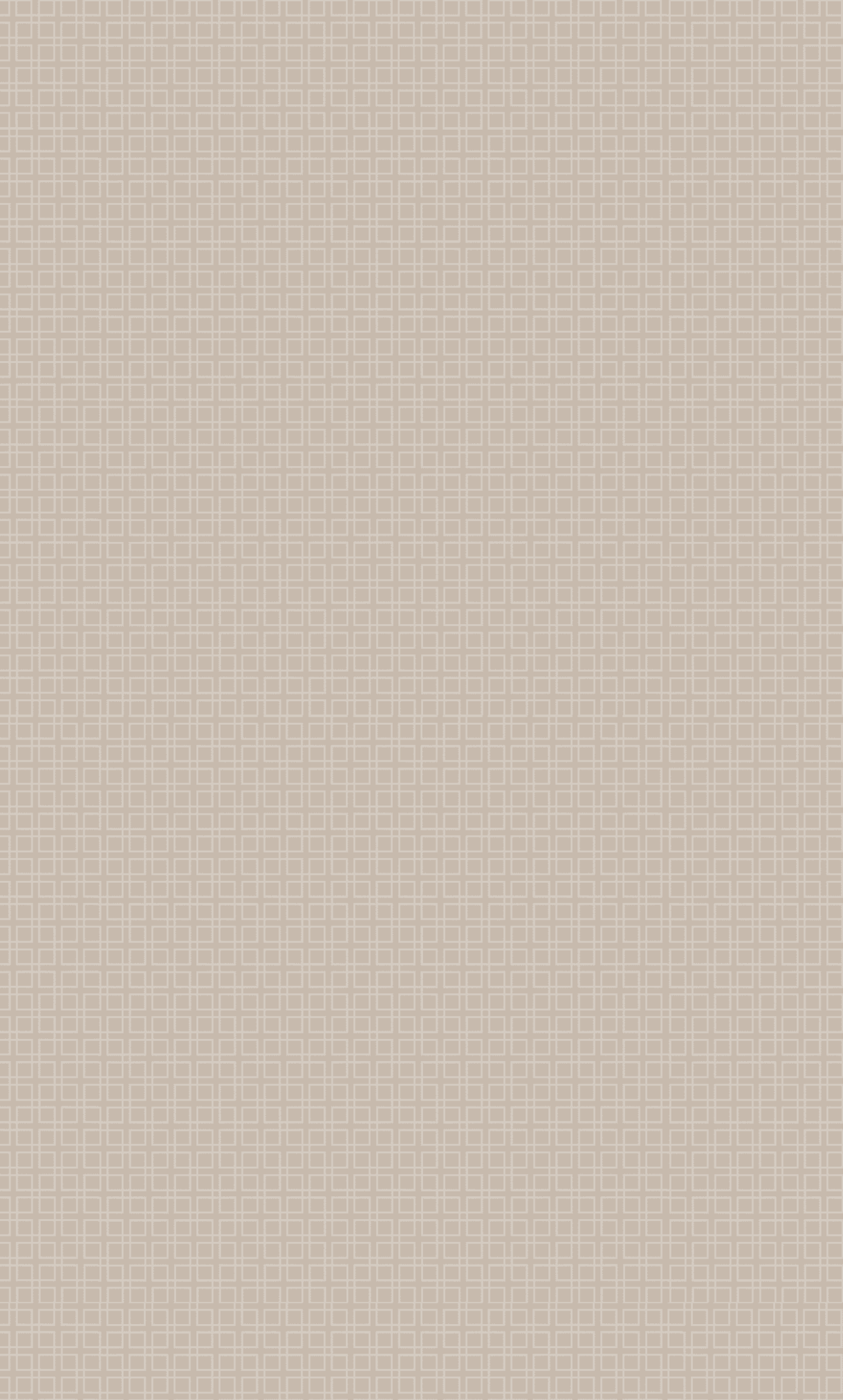

PARCHETTIFICIO GARBELOTTO s.r.l.

via Mescolino, 12 - Z.I.

31012 Cappella Maggiore / TV - Italy

tel. +39 0438 580348 r.a.

info@garbelotto.it

www.garbelotto1950.it



Agente Di Zona/Rivenditore Autorizzato - Area Agent/Authorized Dealer